

5(96)/2018

РЕЦЕНЗИРУЕМОЕ ИЗДАНИЕ

# ИНФОРМАЦИОННО-УПРАВЛЯЮЩИЕ СИСТЕМЫ

**Учредитель**  
ООО «Информационно-управляющие системы»

**Издатель**  
Санкт-Петербургский государственный университет  
аэрокосмического приборостроения

**Главный редактор**  
М. Б. Сергеев,  
д-р техн. наук, проф., Санкт-Петербург, РФ

**Зам. главного редактора**  
Е. А. Крук,  
д-р техн. наук, проф., Москва, РФ

**Ответственный секретарь**  
О. В. Муравцова

**Редакционная коллегия:**  
С. Д. Андреев,  
канд. техн. наук, Тампере, Финляндия  
В. Г. Анисимов,  
д-р техн. наук, проф., Санкт-Петербург, РФ  
Б. П. Безручко,  
д-р физ.-мат. наук, проф., Саратов, РФ  
Н. Блаунштейн,  
д-р физ.-мат. наук, проф., Беэр-Шева, Израиль  
Л. С. Джайн,  
д-р наук, проф., Канберра, Австралия  
А. Н. Дудин,  
д-р физ.-мат. наук, проф., Минск, Беларусь  
И. И. Думер,  
д-р наук, проф., Риверсайд, США  
А. И. Зейфман,  
д-р физ.-мат. наук, проф., Вологда, РФ  
К. Кристофолу,  
д-р наук, проф., Альбукерке, Нью-Мексико, США  
Г. Н. Мальцев,  
д-р техн. наук, проф., Санкт-Петербург, РФ  
Г. Г. Матвиенко,  
д-р физ.-мат. наук, проф., Томск, РФ  
В. Ф. Мелехин,  
д-р техн. наук, проф., Санкт-Петербург, РФ  
А. А. Мюллери  
д-р наук, профессор, Гренада, Вест-Индия  
Ю. Ф. Подоплёкин,  
д-р техн. наук, проф., Санкт-Петербург, РФ  
Т. Сутикнуоу  
д-р наук, доцент, Джокарта, Индонезия  
Д. Себерри,  
д-р наук, проф., Волонгонг, Австралия  
А. В. Смирнов,  
д-р техн. наук, проф., Санкт-Петербург, РФ  
М. Н. Фаворская,  
д-р техн. наук, проф., Красноярск, РФ  
Л. Фортуна,  
д-р наук, проф., Катания, Италия  
А. Л. Фрадков,  
д-р техн. наук, проф., Санкт-Петербург, РФ  
В. И. Хименко,  
д-р техн. наук, проф., Санкт-Петербург, РФ  
А. Е. Храмов,  
д-р техн. наук, проф., Саратов, РФ  
А. А. Шальто,  
д-р техн. наук, проф., Санкт-Петербург, РФ  
А. А. Шелупанов,  
д-р техн. наук, проф., Томск, РФ  
А. П. Шепета,  
д-р техн. наук, проф., Санкт-Петербург, РФ  
Ю. И. Шокин,  
акад. РАН, д-р физ.-мат. наук, проф., Новосибирск, РФ  
З. М. Юлдашев,  
д-р техн. наук, проф., Санкт-Петербург, РФ  
Р. М. Юсупов,  
чл.-корр. РАН, д-р техн. наук, проф., Санкт-Петербург, РФ

**Редактор:** А. Г. Ларионова  
**Корректор:** Т. В. Звертановская  
**Дизайн:** М. Л. Черненко, Ю. В. Умницына  
**Компьютерная верстка:** Ю. В. Умницына

**Адрес редакции:** 190000, Санкт-Петербург,  
Б. Морская ул., д. 67, ГУАП, РИЦ  
Тел.: (812) 494-70-02, эл. адрес: ius.spb@gmail.com,  
сайт: http://i-us.ru

**ОБРАБОТКА ИНФОРМАЦИИ И УПРАВЛЕНИЕ**

**Лашков И. Б.** Подход к распознаванию стиля вождения водителя транспортного средства на основе использования сенсоров смартфона 2

**ИНФОРМАЦИОННО-УПРАВЛЯЮЩИЕ СИСТЕМЫ**

**Бураков М. В., Коновалов А. С.** Нечеткий супервизор ПИД-регулятора 13

**МОДЕЛИРОВАНИЕ СИСТЕМ И ПРОЦЕССОВ**

**Мальцев Г. Н., Якимов В. Л., Соловьев С. В., Лебедева Н. В.** Первичная обработка телеметрической информации с использованием динамических моделей изменения параметров и парциальной нелинейной фильтрации 22

**Татарникова Т. М.** Статистические методы исследования сетевого трафика 35

**ЗАЩИТА ИНФОРМАЦИИ**

**Шумская О. О., Железны М.** Адаптивный алгоритм встраивания информации в сжатые JPEG-изображения на основе операции замены 44

**Штанько С. В.** Ограничение несанкционированного доступа в радиотехнических системах с широкополосной передачей информации 57

**КОДИРОВАНИЕ И ПЕРЕДАЧА ИНФОРМАЦИИ**

**Таубин Ф. А.** Решетчатые сигнально-кодовые конструкции для каналов с линейными искажениями 66

**Sinjuk A. D., Ostroumov O. A.** Theorem about key capacity of a communication network 79

**Pastushok I. A.** Efficiency evaluation of scheduling algorithms for delay-sensitive traffic in OFDM downlink 88

**ИНФОРМАЦИОННЫЕ КАНАЛЫ И СРЕДЫ**

**Sergeev A. M., Blaunstein N. Sh.** Evolution of multiple-access networks – cellular and non-cellular – in historical perspective. Part 2 94

**УПРАВЛЕНИЕ В МЕДИЦИНЕ И БИОЛОГИИ**

**Maksimenko V. A., Runnova A. E., Kulanin R. A., Protasov P. A., Zhuravlev M. O., Chholak P., Pisarchik A., Hramova A. E.** Algorithm for automatic estimation of human brain activity features during mental task evaluation 104

**УПРАВЛЕНИЕ В СОЦИАЛЬНО-ЭКОНОМИЧЕСКИХ СИСТЕМАХ**

**Лада А. Н., Майоров И. В.** Мультиагентный метод построения сменно-суточных заданий для задачи планирования производственных ресурсов в реальном времени 112

**СВЕДЕНИЯ ОБ АВТОРАХ**

120

Журнал входит в БД SCOPUS, в RSCI на платформе Web of Science и в Перечень рецензируемых научных изданий, в которых должны быть опубликованы основные научные результаты диссертаций на соискание ученой степени кандидата наук, на соискание ученой степени доктора наук.

Сдано в набор 05.09.18. Подписано в печать 22.10.18. Формат 60×84/8. Гарнитура SchoolBookC. Печать цифровая. Усл. печ. л. 14,5. Уч.-изд. л. 20,1. Тираж 1000 экз (1-й завод 120 экз.). Заказ № 449.

Оригинал-макет изготовлен в редакционно-издательском центре ГУАП. 190000, Санкт-Петербург, Б. Морская ул., 67.

Отпечатано с готовых диапозитивов в редакционно-издательском центре ГУАП. 190000, Санкт-Петербург, Б. Морская ул., 67.

Журнал распространяется по подписке. Подписку можно оформить через редакцию, а также в любом отделении связи по каталогу «Роспечать»: № 15385 — полугодовой индекс.

Журнал зарегистрирован в Министерстве РФ по делам печати, телерадиовещания и средств массовых коммуникаций. Свидетельство о регистрации ПИ № 77-12412 от 19 апреля 2002 г. Перерегистрирован в Роскомнадзоре. Свидетельство о регистрации ПИ № ФС77-49181 от 30 марта 2012 г. © Коллектив авторов, 2018

UDC 621.396

doi:10.31799/1684-8853-2018-5-88-93

## Efficiency evaluation of scheduling algorithms for delay-sensitive traffic in OFDM downlink

I. A. Pastushok<sup>a</sup>, PhD, Tech., Senior Lecture, [orcid.org/0000-0002-3296-562X](https://orcid.org/0000-0002-3296-562X), [i.pastushok@k36.org](mailto:i.pastushok@k36.org)

<sup>a</sup>Saint-Petersburg State University of Aerospace Instrumentation, 67, B. Morskaya St., 190000, Saint-Petersburg, Russian Federation

**Introduction:** Common introduction of industrial control systems based on wireless networks leads to the emergence of a new way of using wireless networks, called the Industrial Internet of Things (IIoT). This framework assumes a large but finite number of users for which you have to provide the transmission of short messages with low delay and limited delay variation. **Purpose:** Efficiency evaluation of resource allocation algorithms for delay-sensitive traffic in a downlink OFDM channel. **Methods:** An OFDM system is presented as a set of  $M/G/1$  queuing systems. A convex optimization problem is introduced, whose solution determines the lower bound of the average delay of message transmission in delay-sensitive traffic over the set of scheduling algorithms under study. **Results:** An algorithm is proposed for calculating the lower bound of the average delay. This algorithm is fed by system parameters: the average message size, the input flow intensity, and the average maximum throughput for each device connected to the base station. Based on these input parameters, the optimization problem is introduced and solved by a numerical method. The solution of the optimization problem determines the lower bound of the average message transmission delay. **Practical relevance:** The obtained result can be used by system developers for planning and deploying OFDM networks. It can also serve as a reference when developing Ultra-Reliable and Low Latency Communication technology.

**Keywords** – industrial internet of things, OFDM, average delay, queuing systems, mathematical optimization, URLLC.

**Citation:** Pastushok I. A. Efficiency evaluation of scheduling algorithms for delay-sensitive traffic in OFDM downlink. *Informatsionno-upravliayushchie sistemy* [Information and Control Systems], 2018, no. 5, pp. 88–93. doi:10.31799/1684-8853-2018-5-88-93

### Introduction

Wireless technologies are now widely introduced into industry, leading to the emergence of a new way of using wireless networks, called the Industrial Internet of Things (IIoT). This way assumes that there are multiple devices which establish a wireless connection to a remote server. The server uses a sequence of control messages transmitted over a downlink to remotely control and monitor a particular technological process or the enterprise as a whole [1–3].

Within the IIoT concept framework, the International Telecommunication Committee [4] and 3GPP consortium [5] are standardizing the network scenario of Ultra-Reliable and Low Latency Communication (URLLC) designed to satisfy the key performance indicators for the industry. However, the 3GPP consortium has just started this standardization procedure.

It is worth noting that a number of studies are known, tasked with reviewing [6] or theoretical analysis [7] of URLLC scenario for 5G networks. In [6] and [7], the authors discuss possible usage of non-orthogonal multiple access technology to achieve key performance indicators of a wireless network required for the operation of an information system. Unlike these works, this article aims to obtain efficiency estimates for the existing orthogonal communication systems when a delay-sensitive traffic is transmitted via a downlink channel. This will give the engineers and network developers

a tool for assessing the efficiency of using orthogonal networks when planning and deploying them.

The article is organized as follows. First, we give a description for a model of the system under study, along with a system of assumptions. We analyze the system as a queuing system and formulate an optimization problem whose solution will allow us to find the lower bound of an average message transmission delay in an OFDM system. Then we propose an algorithm for calculating the lower bound of an average delay of downlink message transmission in an OFDM system. Finally, we present some numerical results and conclusions.

### System model

In this article, we discuss a development of the model proposed in [8], applied to delay-sensitive traffic transmission. The networks contains a remote server that coordinates the functioning of a finite number  $N$  of devices connected to the same base station. The functioning of each device  $i$  is coordinated by forming a sequence of messages (each message has a unique serial number  $j$ ) as long as  $V_{i,j}$ ,  $j = \overline{1, \infty}$  bits, and the time intervals between the arrival of messages are distributed according to an exponential law with the parameter  $\lambda_i$  [9]. Via an absolutely reliable channel, the messages are transmitted to the base station (BS) where they get into

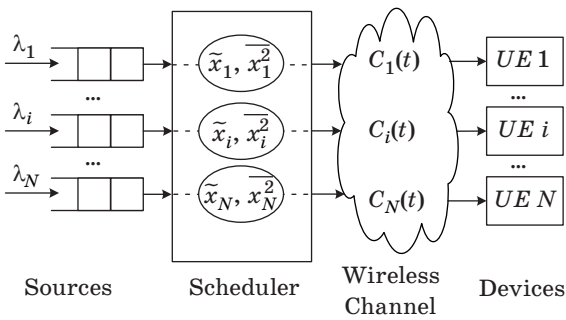

Fig. 1. System model

queues (each queue corresponds to a unique device) to be transmitted via a wireless channel (see Fig. 1).

**General statements**

We discuss the operation of a downlink in OFDM mode: all the operation time is split into slots of an equal duration; within a slot, a limited frequency zone can be distributed between several devices. Because of flat fading in the wireless channel, its state changes in time for each device: in each time moment  $t$ , the channel state can be represented as a vector  $C(t) = [C_i(t), i = \overline{1, N}]$ , where  $C_i(t)$  is the speed of transmitting data for the device  $i$  if it is given all the frequency zone for transmission at the time moment  $t$ .

The BS scheduler whose task is distributing the fractions of the wireless channel between the devices makes a decisive contribution to the system efficiency. The scheduler task solution can be described with a vector  $\alpha(t) = [\alpha_i(t), i = \overline{1, N}]$ , where  $\alpha_i(t)$  is the frequency zone fraction given to the device  $i$  at the time moment  $t$ . An obvious limitation is that the available frequency band for data transmission is finite:

$$\forall t: \sum_{i=1}^N \alpha_i(t) \leq 1. \tag{1}$$

The main efficiency indicators for delay-sensitive traffic are [5, 4]:

- average delay of message transmission for the device  $i$ , see the expression (2);
- delay dispersion for message transmission via the wireless channel.

The delay dispersion can be large because the resources for data transmission are given irregularly. This is considered to be a negative effect. Therefore, the delay dispersion is limited from above by a certain value.

The average delay of message transmission is determined by the following expression:

$$\overline{T}_i = \lim_{\tau \rightarrow \infty} \frac{1}{H_i(\tau)} \sum_{j=1}^{H_i(\tau)} T_{i,j}, \tag{2}$$

where  $H_i(\tau)$  is the number of fully delivered messages for the device  $i$  during the time interval  $[0, \tau]$ , and  $T_{i,j}$  is the time interval from the moment when a message  $j$  for the device  $i$  gets into a BS queue, to the moment when the last bit of the message is received by the device  $i$ . In its turn, the value  $T_{i,j}$  consists of the duration of waiting for a message in the BS queue ( $w_{i,j}$ ) and the duration of transmitting the message via the wireless channel ( $x_{i,j}$ ):

$$T_{i,j} = w_{i,j} + x_{i,j}. \tag{3}$$

Note that as a result of the scheduler's operation, during the transmission of a message  $j$  for the device  $i$ , the value of  $x_{i,j}$ , is determined which directly affects the waiting time in the queue for the subsequent messages. This process is demonstrated in Fig. 2.

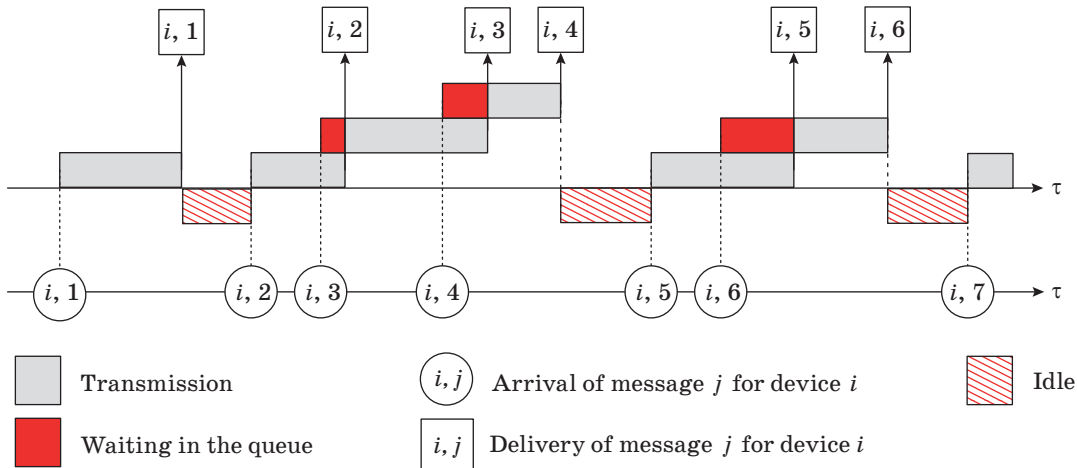

Fig. 2. Graphical representation of delivering messages for device  $i$

The generalized result of the scheduler's operation for each user  $i$  are pairs of values  $\widetilde{x}_i$  (average delay in message transmission) and  $\overline{x}_i^2$  (coefficient of variation in message transmission).

**Assumptions**

In this article, we use the following assumptions:

- $\forall i: V_{i,j}, j=1, \infty$  is an ergodic random process with finite mathematical expectation  $\overline{V}_i$ .
- $\forall i: x_{i,j}, j=1, \infty$  is a sequence of identically distributed random values independent from each other and from the input flow; their mathematical expectation is  $\widetilde{x}_i$  and coefficient of variation is  $\overline{x}_i^2$ .
- The wireless channel state changes in such a way that the following equality holds:

$$\int_{t_{i,j}}^{t_{i,j}+x_{i,j}} \alpha_i(t) C_{i,j}(t) dt = C_{i,j} \int_{t_{i,j}}^{t_{i,j}+x_{i,j}} \alpha_i(t) dt = V_{i,j}, \quad (4)$$

where  $t_{i,j}$  is the time when a message  $j$  starts to be transmitted to the device  $i$ .

- $\forall i: C_{i,j}^{-1}, j=1, \infty$  is an ergodic random process with finite mathematical expectation  $\overline{C}_i^{-1}$ .

The presented description of the system and the assumptions introduced above describe an infinite and uncountable set of hypothetical planning algorithms  $\mathcal{A}$  with possible analytical estimates.

**Analysis of the system**

In this section, we analyze the system under study as a queuing system, and formulate an optimization problem whose solution will characterize the efficiency of OFDM systems in delay-sensitive message transmission.

**The system model as a queuing system**

With the assumptions made above, the system can be represented as a combination of  $N$  queues M/G/1, where each queue corresponds to a unique device. An average delay of message transmission for device  $i$  (see expressions (2) and (3)) can be found by the Pollaczek — Khinchin formula [10]:

$$\overline{T}_i = \widetilde{x}_i + \frac{\lambda_i \overline{x}_i^2}{2(1 - \lambda_i \widetilde{x}_i)}. \quad (5)$$

Thus we obtained an expression for an average delay of message transmission for device  $i$  ( $\overline{T}_i$ ) as a function of an average duration of message transmission via the wireless channel for the user  $i$  ( $\widetilde{x}_i$ ).

An important parameter of the system is the average idle time for the M/G/1 queue per message,

which is determined by the following expression [11]:

$$\overline{I}_i = \frac{1}{\lambda_i}. \quad (6)$$

**Formulation of the optimization problem**

One of the central results of [8] is the interrelation between the characteristics of a wireless centralized communication network and the quality of user service when transmitting video data by the HTTP protocol. With reasoning similar to that in [8], we can find a real interrelation in terms of the system under study.

**Lemma.** For a set of scheduling algorithms  $\mathcal{A}$  satisfying the introduced assumptions, the following inequality is true:

$$\sum_{i=1}^N \frac{\overline{V}_i \overline{C}_i^{-1}}{\widetilde{x}_i + \overline{I}_i} \leq 1. \quad (7)$$

The proof of this Lemma is similar to the proof given in [8]. Therefore, it is not given in this article.

Let us define the efficiency index of an OFDM system transmitting delay-sensitive traffic as an average value of message transmission delay over the entire set of devices with a given coefficient of variation for each particular device:  $T(\mathcal{A}) = \sum_{i=1}^N \overline{T}_i(\mathcal{A})$ .

It is important to note that the value of the message transmission delay is determined by a specific scheduling algorithm  $A$  installed on the BS.

Let us introduce the problem of estimating the efficiency of an OFDM system as a problem of finding the lower bound of an average message transmission delay over the set of scheduling algorithms  $\mathcal{A}$ :

$$\widetilde{T} = \inf_{A \in \mathcal{A}} T(A). \quad (8)$$

The value of the lower bound of an average message transmission delay can be obtained as a solution to a nonlinear optimization problem (9).

$$\text{Minimize: } T^* = \frac{1}{N} \sum_{i=1}^N \left( \widetilde{x}_i + \frac{\lambda_i \overline{x}_i^2}{2(1 - \lambda_i \widetilde{x}_i)} \right) \quad (9)$$

$$\text{Subject to: } \begin{cases} \sum_{i=1}^N \frac{\overline{V}_i \overline{C}_i^{-1}}{\widetilde{x}_i + (\lambda_i)^{-1}} - 1 \leq 0 \\ \widetilde{x}_i \in [0, (\lambda_i)^{-1}], i = \overline{1, N} \end{cases}$$

where  $\widetilde{x}_i, i = \overline{1, N}$  are the optimized parameters,  $\lambda_i$  and  $\overline{V}_i$  are characteristics of the input data flow



for device  $i$ ,  $\tilde{C}_i^{-1}$  is a characteristic of the state of the wireless channel for the user  $i$ , and  $\overline{x_i^2}$  is the coefficient of variation specified for the duration of message transmission via the wireless channel for the device  $i$ .

**Lower bound of average message transmission delay in an OFDM system**

The optimization problem (9) belongs to the class of convex nonlinear programming problems. However, due to the sophisticated structure of the objective function, it is difficult to obtain a closed expression for the lower bound value. Therefore, in this work, we will use numerical methods to solve the optimization problems. In convex optimization problems, they allow you to find the global extremum point of an objective function with limitations [12, 13].

However, the use of a numerical procedure for finding an extremum can be computationally expensive. Therefore, below we analyze the cases when the lower bound value can be obtained without a numerical procedure. Here is a consecutive analysis of the optimization problem (9).

Consider the case when the inequality  $\sum_{i=1}^N \tilde{V}_i \tilde{C}_i^{-1} \lambda_i - 1 \leq 0$  holds. Then an apparent solution of the optimization problem (9) is  $\tilde{x}_i = 0, i = \overline{1, N}$  and  $T^* = 0$ .

Next, let us use the solution method based on the dual Lagrange function [12]. To this end, we introduce an auxiliary function  $f^*$ :

$$f^*(\tilde{x}) = \begin{cases} \frac{1}{N} \sum_{i=1}^N \left( \tilde{x}_i + \frac{\lambda_i \overline{x_i^2}}{2(1-\lambda_i \tilde{x}_i)} \right), & \tilde{x}_i \in \tilde{X} \\ \infty, & \text{otherwise} \end{cases}, \quad (10)$$

where  $\tilde{X}$  is a set of admissible values of the parameter  $\tilde{x}_i \in [0, (\lambda_i)^{-1}]$ ,  $i = \overline{1, N}$ .

Using the expression (10), we can represent the optimization problem as follows:

$$\begin{aligned} &\text{Minimize: } f^*(\tilde{x}) \\ &\text{Subject to: } \quad \quad \quad , \quad (11) \\ &\left\{ \sum_{i=1}^N \frac{K_i}{\tilde{x}_i + (\lambda_i)^{-1}} - 1 \leq 0 \right. \end{aligned}$$

where  $K_i = \tilde{V}_i \tilde{C}_i^{-1}$ ,  $i = \overline{1, N}$ .

The Lagrange function for the optimization problem (11) takes the following form:

$$\begin{aligned} L(\tilde{x}, \mu) = &\frac{1}{N} \sum_{i=1}^N \left( \tilde{x}_i + \frac{\lambda_i \overline{x_i^2}}{2(1-\lambda_i \tilde{x}_i)} \right) + \\ &+ \mu \left[ \sum_{i=1}^N \frac{K_i}{\tilde{x}_i + (\lambda_i)^{-1}} - 1 \right]. \quad (12) \end{aligned}$$

The dual Lagrange function for the expression (12) has the following form:

$$\begin{aligned} g(\mu) = &-\mu + \inf_{x \in \tilde{X}} \frac{1}{N} \sum_{i=1}^N \left( \tilde{x}_i + \frac{\lambda_i \overline{x_i^2}}{2(1-\lambda_i \tilde{x}_i)} + \frac{\mu K_i N}{\tilde{x}_i + (\lambda_i)^{-1}} \right) = \\ = &-\mu + \sum_{i=1}^N \frac{\mu K_i \lambda_i}{2} = \mu \left( \sum_{i=1}^N \frac{K_i \lambda_i}{2} - 1 \right). \quad (13) \end{aligned}$$

On the base of expression (13), the problem of finding the lower bound can be represented as a solution of the optimization (8) problem (14) [12].

$$\begin{aligned} &\text{Maximize: } \mu \left( \sum_{i=1}^N \frac{K_i \lambda_i}{2} - 1 \right) \\ &\text{Subject to: } \quad \quad \quad \cdot \quad (14) \\ &\{ \mu \geq 0 \} \end{aligned}$$

The solution of the optimization problem (14) is the following expression.

$$\tilde{x}^* = \begin{cases} 0, & \sum_{i=1}^N \frac{K_i \lambda_i}{2} \leq 1 \\ \infty, & \text{otherwise} \end{cases}. \quad (15)$$

The expression (15) determines the bound of the non-existence of scheduling algorithms which satisfy the introduced assumptions.

Based on the reasoning presented in this section, we introduce the main theorem.

**Theorem.** The lower bound value for an average message transmission delay in an OFDM system over all possible scheduling algorithms which satisfy the assumptions can be calculated as follows:

$$\tilde{T} = \begin{cases} 0, & \sum_{i=1}^N K_i \lambda_i \leq 1 \\ \infty, & \sum_{i=1}^N \frac{K_i \lambda_i}{2} \geq 1 \\ \chi \left( K_i, \lambda_i, \overline{x_i^2}, i = \overline{1, N} \right), & \text{otherwise} \end{cases},$$

where  $\chi(\cdot)$  is a solution of the optimization problem by a numerical method with the given accuracy.

### Numerical example

The obtained results are demonstrated on the base of LTE system parameters. We consider the functioning of one cell in which users are placed with an equal step on their way from the base station. The maximum achievable user's data transmission rate is in the area from 0.5 MB/s to 5 MB/s, which corresponds to 5 MHz bandwidth [14].

Fig. 3 demonstrates how the lower bound value depends on the number of users in a cell when the size of the transmitted messages is 4 B and the arrival rate is 250 per second for each user in the cell. At the qualitative level, the following statement is true: for given network parameters, there is no scheduling algorithm which provides an average message transmission delay of 5ms when there are 450 users in a cell.

Fig. 4 demonstrates the values of the obtained lower boundaries with fixed input flow intensities for various message sizes. From the calculation for the network scenario described above it follows that with a fixed value of the average message trans-

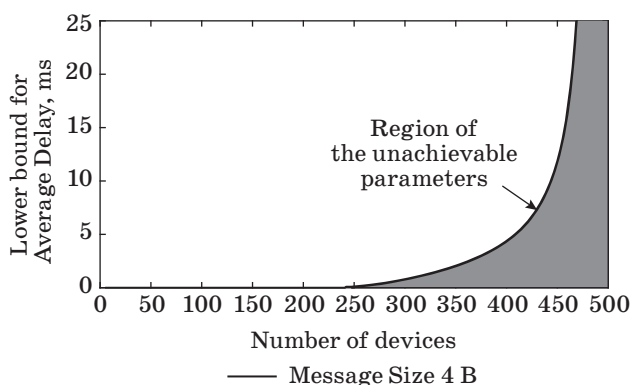

■ Fig. 3. Dependence of the lower bound value on the number of devices when  $V_i = 4$  B

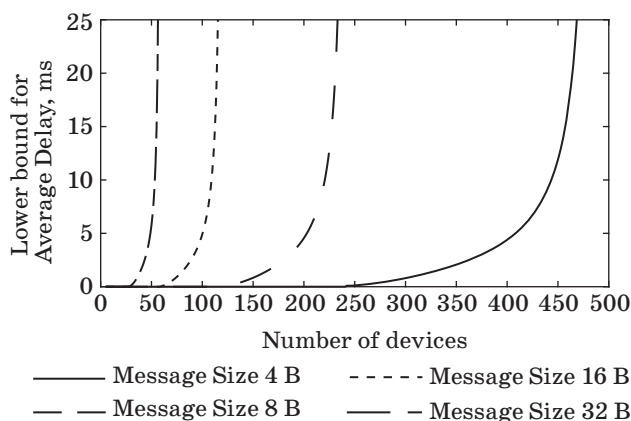

■ Fig. 4. Dependence of the lower bound values on the number of devices for various message sizes

mission delay, the maximum number of subscribers with a possible scheduling algorithm from the set  $\mathcal{A}$  decreases linearly with the message size.

### Conclusion

An algorithm is proposed for calculating the lower bound value for an average message transmission delay in OFDM systems. The obtained result allows Internet communication system developers to plan OFDM systems deployed in industry. It can also serve as a reference for communication systems that provide URLLC.

The author is supported by scientific project No 8.8540.2017 «Development of data transmission algorithms in IoT systems with limitations on the devices complexity».

### References

1. Wan J., Tang S., Shu Z., Li D., Wang S., Imran M., Vasilakos A. V. Software-defined industrial internet of things in the context of industry 4.0. *IEEE Sensors Journal*, 2016, no 20, pp. 7373–7380. doi:10.1109/JSEN.2016.2565621
2. Shrouf F., Ordieres J., Miragliotta G. Smart factories in Industry 4.0: A review of the concept and of energy management approached in production based on the Internet of Things paradigm. *2014 IEEE International Conference on Industrial Engineering and Engineering Management*, 2014, pp. 697–701. doi:10.1109/IEEM.2014.7058728
3. Chen B., Wan J., Shu L., Li P., Mukherjee M., Yin B. Smart factory of industry 4.0: key technologies, application case, and challenges. *IEEE Access*, 2018, vol. 6, pp. 6505–6519. doi:10.1109/ACCESS.2017.2783682
4. ITU-R M.2083-0. IMT Vision — framework and overall objectives of the future development of IMT for 2020 and beyond. *ITU-R*, 2015. 21 p.
5. 3GPP TS 22.261 16.4.0. Service requirements for next generation new services and markets. *3GPP*, 2017. 55 p.
6. Bennis M., Debbah M., Poor V. *Ultra-reliable and low-latency wireless communication: tail, risk and scale*. 2018. Available at: <https://arxiv.org/pdf/1801.01270.pdf> (accessed 12 September 2018).
7. Popovski P., Trillingsgaard K., Simeone O., Durisi G. *5G wireless network slicing for eMBB, URLLC, and mMTC: A communication-theoretic view*. 2018. Available at: <https://arxiv.org/pdf/1804.05057.pdf> (accessed 12 September 2018).
8. Pastushok I., Bakin E. On interrelation of video streaming characteristics in centralized wireless networks. *IEEE wireless communications letters*, 2018,

- vol. 7, no. 2, pp. 226–229. doi:10.1109/LWC.2017.2767597
9. 3GPP TR 36.872 V12.1.0. Small cell enhancements for E-UTRA and E-UTRAN — Physical layer aspects. *3GPP*, 2013. 100 p.
  10. Khinchin A. Matematicheskaya teoriya stacionarnoi ocheredi. *Matematicheskii sbornik*, 1932, vol. 39, no. 4, pp. 73–84 (In Russian).
  11. Kleinrock L. *Theory. Volume 1. Queueing systems*. Wiley-Interscience, 1975. 417 p.
  12. Boyd S., Vandenberghe L. *Convex optimization*. Cambridge University Press, 2004. 716 p.
  13. Byrd R. H., Gilbert J. C., Nocedal J. A trust region method based on interior point techniques for nonlinear programming. *Mathematical programming*. 2000, vol 89, no 1, pp. 149–185. doi:10.1007/s101070000189
  14. Sesia S., Toufik I., Baker M. *Lte, the UMTS long term evolution: from theory to practice*. Wiley Publishing, 2009. 752 p.

УДК 621.396

doi:10.31799/1684-8853-2018-5-88-93

### Оценка эффективности алгоритмов планирования для передачи чувствительного к задержке трафика по нисходящему каналу в режиме OFDM

И. А. Пастушок<sup>а</sup>, канд. техн. наук, старший преподаватель, orcid.org/0000-0002-3296-562X, i.pastushok@k36.org

<sup>а</sup>Санкт-Петербургский государственный университет аэрокосмического приборостроения, Б. Морская ул., 67, Санкт-Петербург, 190000, РФ

**Введение:** повсеместное внедрение систем управления, основанных на беспроводной связи, в промышленных объектах формирует специфичный сценарий использования беспроводных систем, который получил название Индустриальный интернет вещей. В рамках данного сценария предполагается наличие большого, но конечного числа пользователей, для которых должна быть обеспечена передача коротких сообщений с низкой задержкой и ограничением на дисперсию задержки. **Цель исследования:** оценка эффективности алгоритмов планирования распределения частотно-временных ресурсов для систем связи с ортогональным частотным мультиплексированием каналов (OFDM) при передаче чувствительного к задержке трафика в нисходящем канале связи. **Методы:** система OFDM представлена в виде множества систем массового обслуживания M/G/1, произведена постановка оптимизационной задачи, решение которой определяет нижнюю границу средней задержки передачи сообщений чувствительного к задержке трафика по множеству исследуемых алгоритмов планирования. **Результаты:** предложен алгоритм вычисления значения нижней границы средней задержки передачи сообщений чувствительного к задержкам трафика в системе OFDM. Предложенный алгоритм принимает на вход параметры системы: средний размер сообщения, интенсивность входного потока и среднее значение максимально достижимой скорости передачи данных для каждого устройства, подключенного в базовой станции. На основе введенных параметров системы производится постановка оптимизационной задачи и ее решение численным алгоритмом. Решение оптимизационной задачи определяет значение нижней границы средней задержки передачи сообщений по множеству исследуемых алгоритмов планирования в нисходящем канале связи систем OFDM. **Практическая значимость:** полученный результат может быть использован разработчиками систем при планировании и развертывании OFDM сетей, а также является опорным результатом для разрабатываемой технологии сверхнадежной связи с низкими задержками (URLLC).

**Ключевые слова** — индустриальный интернет вещей, OFDM, средняя задержка, теория массового обслуживания, математическая оптимизация, URLLC.

**Цитирование:** Pastushok I. A. Efficiency evaluation of scheduling algorithms for delay-sensitive traffic in OFDM downlink. *Информационно-управляющие системы*, 2018, № 5, с. 88–93. doi:10.31799/1684-8853-2018-5-88-93

**Citation:** Pastushok I. A. Efficiency evaluation of scheduling algorithms for delay-sensitive traffic in OFDM downlink. *Informatsionno-upravliaiushchie sistemy* [Information and Control Systems], 2018, no. 5, pp. 88–93. doi:10.31799/1684-8853-2018-5-88-93